



केंद्रीय रेशम प्रौद्योगिक अनुसंधान संस्थान
केंद्रीय रेशम बोर्ड
(वस्त्र मंत्रालय - भारत सरकार)
बी.टी.एम. लेआउट, माडिवाला, बेंगलुरु - ५६० ०६८
CENTRAL SILK TECHNOLOGICAL RESEARCH INSTITUTE
CENTRAL SILK BOARD
(Ministry of Textiles – Govt. of India)
B.T.M. Layout, Madivala, Bengaluru - 560 068



Phone: 080-26685238, 26282190 e-mail: cstriban.csb@nic.in, website: cstri.res.in

No.CSB/CSTRI/ 12(21)/2021-Stores

Date: 05.04.2024

To,

Sir,

Sub: Inviting Quotations for Supply of CSTRI Slit Button consisting of Ceramic Flat, Ceramic Holder Made of Organic Polymers and Torsion Spring-Reg.

With reference to the subject cited above, I am to inform that this Institute invites sealed quotation in two bid system for supply of CSTRI Slit Buttons consisting of Ceramic Flat, Ceramic Holder Made of Organic Polymers and Torsion Spring to **CSTRI,CSB, Bangalore** as per the specification mentioned below:-

#	Item Particulars	Specification	Quantity in numbers
1	Slit Buttons consisting of Ceramic Flat, Ceramic Holder Made of Organic Polymers and Torsion Spring	As per specification enclosed	500

TERMS & CONDITION :

1. The quotation in two bid (Technical Bid & Financial Bid) system should be submitted to The Director, Central Silk Technological Research Institute, B.T.M. Layout, Madivala, Bangalore-560068. The sealed quotation should be superscribed as **“Quotation for supply of Slit Button consisting of Ceramic Flat, Ceramic Holder Made of Organic Polymers and Torsion Spring”** not to be opened on or before **01.05.2024, 2.00 p.m.** The quotations received after the due date and time will be rejected summarily.
 2. The quotations should be sent in two parts i.e, Technical Bid and Financial Bid separately in sealed cover duly superscribed and both these covers put in a bigger cover which should also be sealed and superscribed.
- (I) **Technical bid should contain the following information with documentary proof.**
- a) The Agency is ready to supply the CSTRI Slit Ceramic Buttons as per the specifications for which Declaration pertaining to “No Technical Deviation” should be given in the technical bid.
 - b) The technical bid which does not fulfill the above condition will be treated technically non-responsive and summarily be rejected.

P.T.O.

- (II) **Financial Bid should contain the following informations with documentary proof.**
- a) Financial Bids should consist of UNIT PRICE, Excise Duty Insurance, Packing & Forwarding, Errection & Commissioning, Transportation Charges, applicable GST alongwith Registration Number.
 - b) The total price quoted by the Agency should be valid for 180 days from the date of opening of the Quotation.
 - c) **Price quoted should be for destination of CSTRI, CSB, Bangalore.**
 - d) The bidder should submit the duly filled Bid Securing Declaration form alongwith the quotation (as per the format enclosed) in lieu of EMD.
 - e) Financial bid which does not fulfill the above conditions will be treated financially non-responsive and summarily be rejected.
2. The last date for submission of the sealed quotation is **01.05.2024 at 2.00 p.m.** The quotations will be opened at **3.30 p.m.** on the same day in the presence of the representatives of the Bidder.
 3. No advance will be paid. However, payment will be released within 30 days after receipt of the item in good working condition and confirm to the specifications.
 4. The Supplier shall provide Warranty/Guarantee valid for a minimum period of 12 months from the date of supply of the item. Any defects noticed in the item which is unintentional shall be set right by the supplier at free of cost for good performance of the same.
 5. The Director, CSTRI, Bangalore reserves the right to accept any quotation or reject all the quotations without assigning any reason thereof. The decision of the Director is final and no correspondence will be entertained from any party in this regard.
 6. PAN/TIN/GST number issued by the concerned Departments should be indicated.
 7. The successful bidder should supply the ordered Spare Parts to **CSTRI, CSB, Bangalore** within 45 days from the date of issue of supply order.
 8. **The bidders should submit the Bank Details i.e.Bank A/c.No., Bank Name, Branch, IFSC code. Etc. along with quotation for releasing the payment**

Encl: As

Yours faithfully,

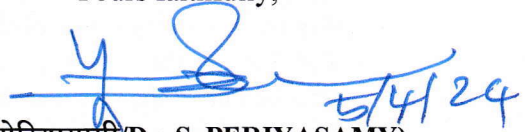
(डॉ. एस.पेरियासामी/Dr. S. PERIYASAMY)
निदेशक \ DIRECTOR

BID SECURING DECLARATION FORM

Tender No. CSB/CSTRI/19(55)/2017-STORES

Date:

To
The Director,
CSTRI,
BANGALORE

I/We, The undersigned, declare that :

I/We understand that, according to your conditions, bids must be supported by a Bid Securing Declaration.

I/We accept that I/We may be disqualified from bidding for any contract with you for a period of one year from the date of notification if I am/We are in a breach of any obligation under the bid conditions, because I / We

- a) have withdrawn / modified/amended, impairs or derogates from the tender, my / our Bid during the period of bid validity specified in the form of Bid ; or
- b) having been notified of the acceptance of our Bid by the purchaser during the period of bid validity (i) fail or reuse to execute the contract, if required, or (ii)fail or reuse to furnish the Performance Security, in accordance with the Instructions to Bidders.

I/We understand this Bid securing Declaration shall cease to be valid if I am / We are not the successful Bidder, upon the earlier of (i) the receipt of your notification of the name of the successful Bidder; or (ii)thirty days after the expiration of the validity of my / our Bid.

Signed:
(Insert Signature of person whose name and capacity are shown)

In the capacity of
(Insert legal capacity of person signing the Bid Securing Declaration)

Name:
(Insert complete name of person signing the Bid Securing Declaration)

Duly authorized to sign the bid for an on behalf of (Insert complete name of Bidder)

Dated on _____ day of _____ (insert date of signing)

Corporate Seal (where appropriate)

(Note: In case of Joint Venture, the Bid Securing Declaration must be in the name of all partners to the Joint Venture that submits the bid)

TECHNICAL SPECIFICATIONS FOR SLIT BUTTON

Slit Button shall consist of following three major parts.

1. CERAMIC FLAT
2. CERAMIC HOLDER MADE OF ORGANIC POLYMERS
3. TORSION SPRING

1. CERAMIC FLAT

Ceramic flat plate shall be made of Al_2O_3 ceramic material. The major silk thread passing slit hole shall be 350 microns diameter and having 150 microns width slit (Fig 1). The plat should have 1.5 mm diameter holes on either side of the slit as per the drawings. The diameter of ceramic plate shall be of 21 mm with 90° cut to form semi circular plate ending the slit. The thickness of the ceramic shall be 1 mm and other details are given in the Figure-1. The silk thread passing hole and slit shall be smooth finish and it shall not have any rough surface. The silk thread passing hole should be circular in shape.

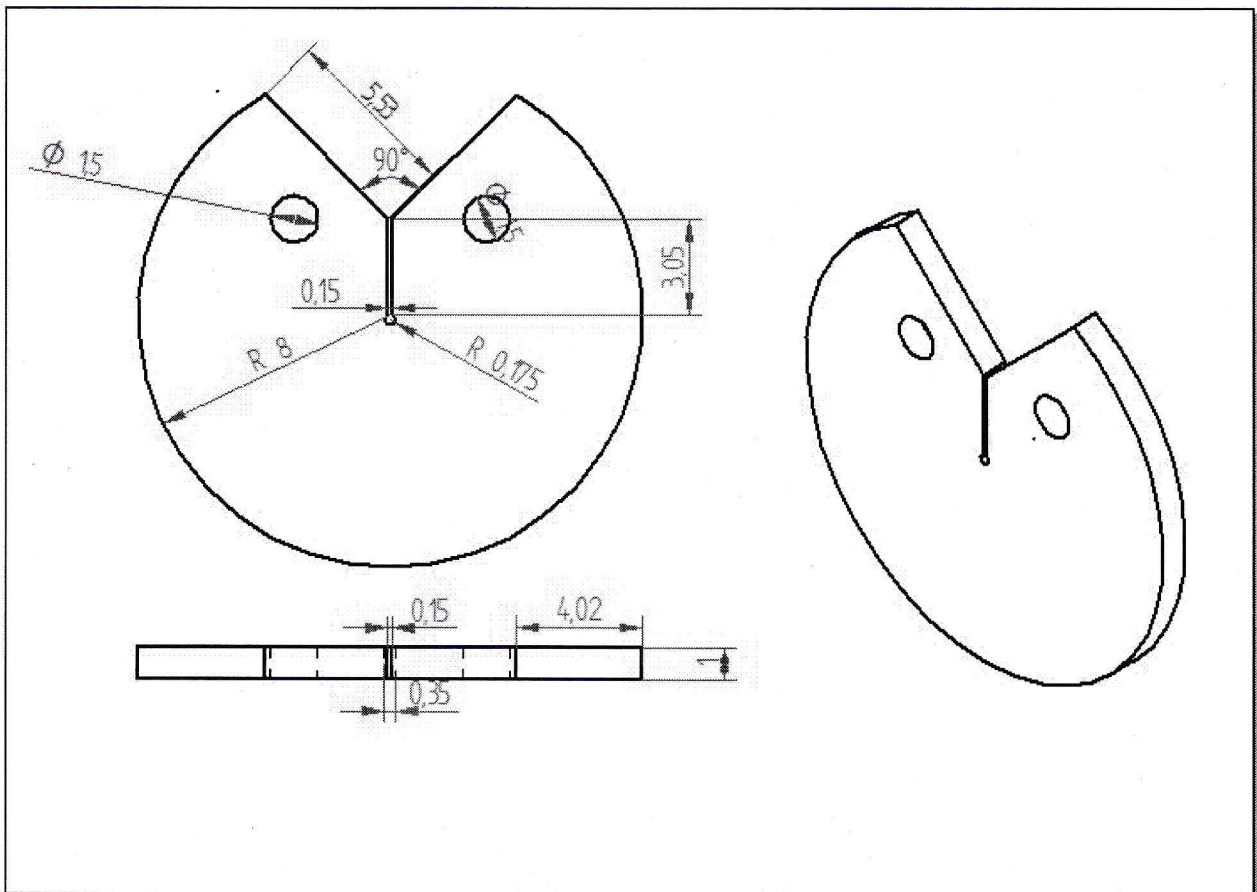

2.

Figure -1.

2. CERAMIC HOLDER MADE OF ORGANIC POLYMERS

Ceramic flat holder shall be made of organic polymers of HDP with 90° angle opening at one side as shown in the Figure-2 with insert molding of ceramic slit button. The provision shall be provided as per the drawings to mount at reeling machine button clips and also should have Torsion spring mounting groove as per the drawing on the top side having a dimension of 21.3 mm diameter.

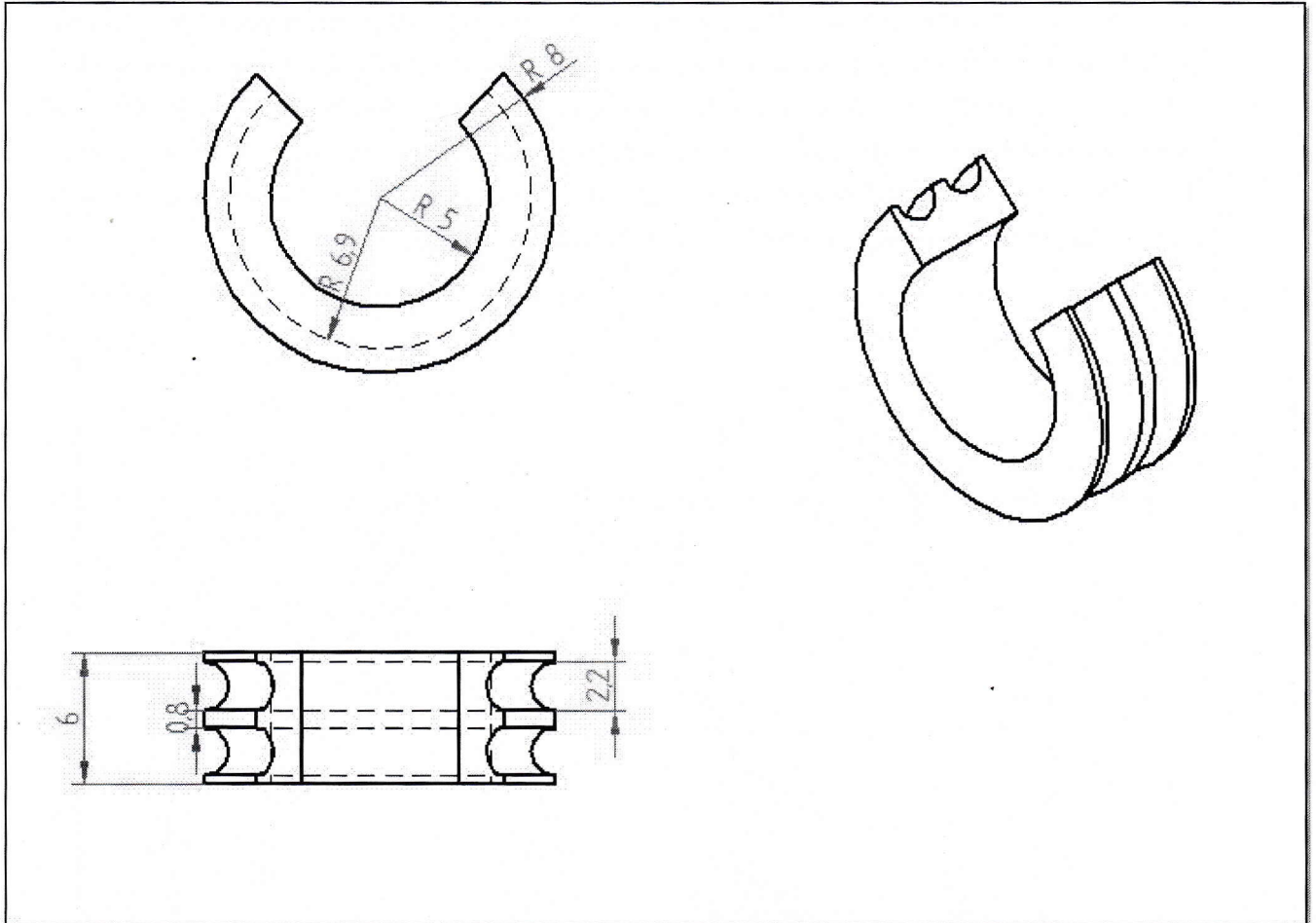

Figure -2.

3. TORSION SPRING

Torsion spring shall be made of corrosion resistance SS wire having a shape shown in Figure -3. The SS wire diameter shall be 1 mm. The circular spring outer to outer diameter should be 20.77 mm. The detailed dimensions are shown in Figure -3.

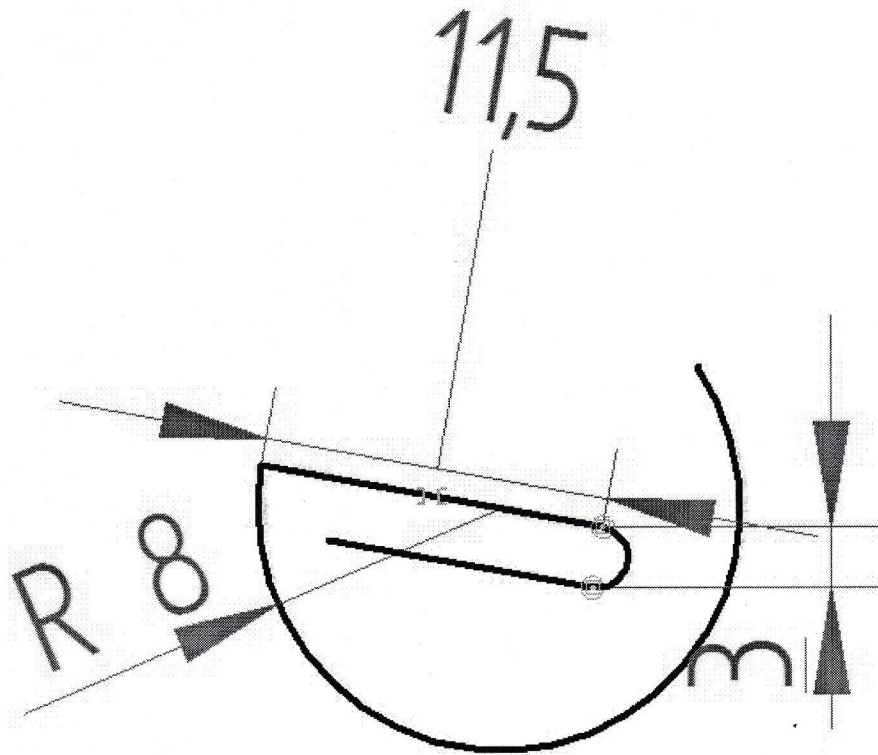

Figure -3.

The Image of the complete assembled with above said three items are shown in the Figure – 4 to 5. For further detailed information and observation of the sample may please contact The Director, CSTRI, Central Silk Board, Bengaluru-560 068 between 9.30 AM to 6 PM during working days

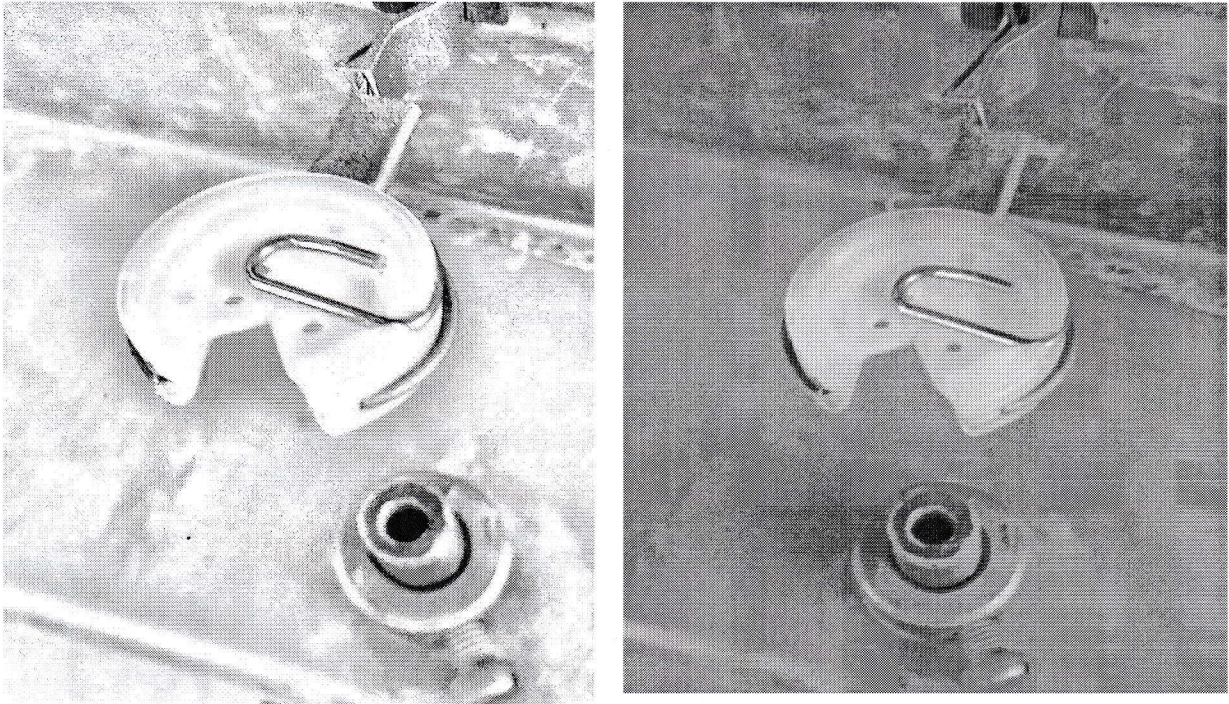

Figure -4.

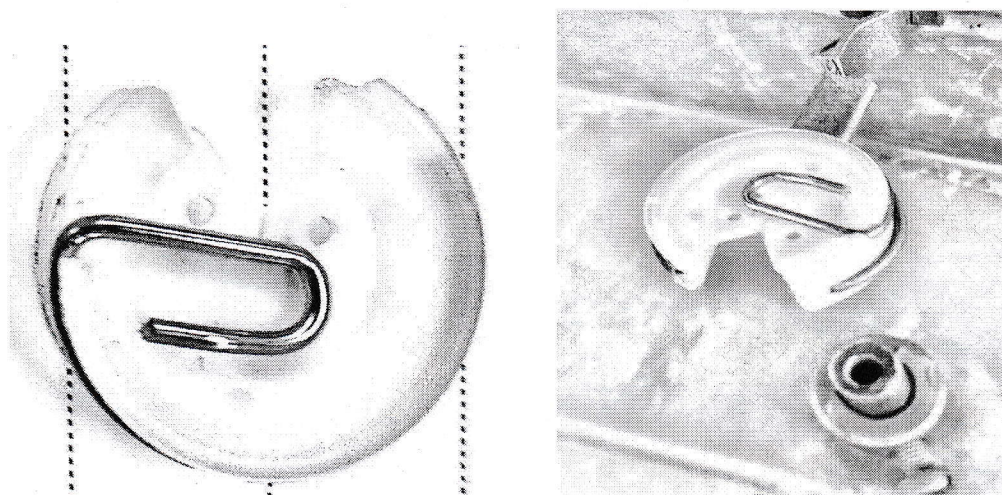

Figure -5.